

# MATEX Powered Lifter Stackers Transporter

1000kg or 1500kg Rated - Rechargeable Battery System

## FEATURING

- ✔ **Effortless Electric Lifting:** Smooth electric lift system allows operators to raise loads with minimal effort, improving efficiency and reducing manual strain.
- ✔ **Compact Design for Tight Workspaces:** Narrow footprint (870mm length) and excellent manoeuvrability make it ideal for warehouses, workshops, and confined areas.
- ✔ **Stable & Reliable Load Handling:** Well-balanced structure with optimised load centre ensures safe and controlled lifting for cartons, tools, and light equipment.
- ✔ **Integrated 24V Rechargeable Battery:** Reliable battery system with power indicator supports consistent daily use without frequent charging interruptions.
- ✔ **User-Friendly & Safe Operation:** Ergonomic controls, emergency stop function, and lockable castors provide precise handling and secure positioning during operation.
- ✔ **Enclosed Chain & Belt Protection System:** Integrated belt cover shields the lifting chain from dust, debris, and external contact, improving durability and ensuring safer operation.
- ✔ **Versatile Across Work Environments:** Suitable for warehouses, workshops, and retail spaces requiring efficient lifting in confined areas.



This specification datasheet is provided for reference purposes only and does not constitute a guarantee of performance or features. The manufacturer reserves the right to make changes without prior notice. For the most accurate and up-to-date information, please refer to the user manual and the labels affixed to the equipment.

**Melbourne Head Office**  
P: (03) 8791 5777  
E: melbourne@teamsystems.net.au

**Sydney Branch**  
P: (02) 9609 7782  
E: sydney@teamsystems.net.au

**Brisbane Branch**  
P: (07) 3807 9144  
E: brisbane@teamsystems.net.au

**Adelaide Branch**  
P: (08) 8340 4111  
E: adelaide@teamsystems.net.au

**Perth Branch**  
P: (08) 9455 4855  
E: perth@teamsystems.net.au

**New Zealand Branch**  
P: 9 887 4647 W: teamsystems.co.nz  
E: auckland@teamsystems.co.nz



# MATEX Powered Lifter Stackers Transporter

1000kg or 1500kg Rated - Rechargeable Battery System

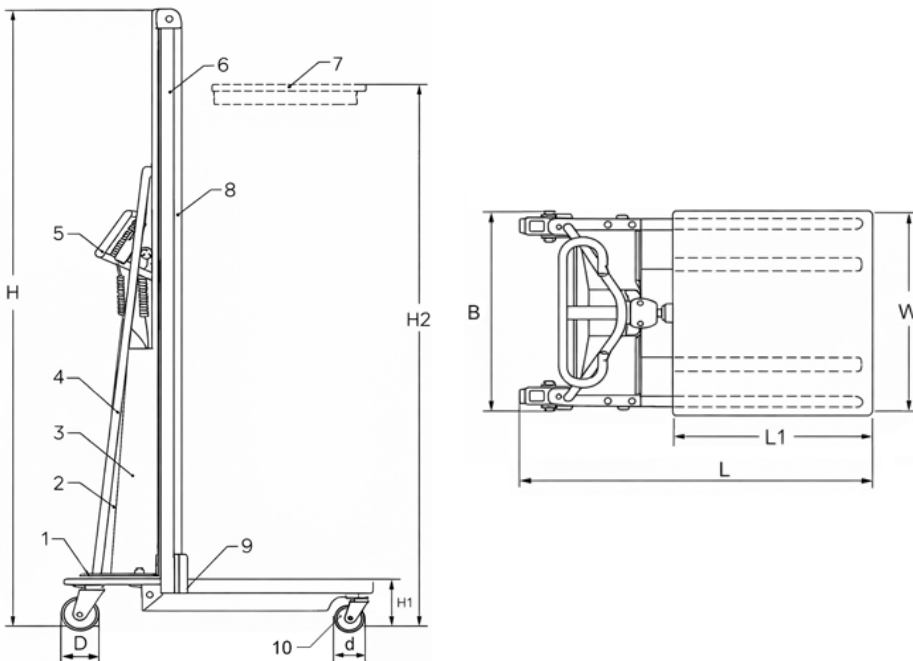

## Key Component

1. Rear Wheel
2. Electric Control of Transmission Box
3. Handrails
4. Movable Handy Panel
5. Aluminum Alloy Pole
6. Safety Belt
7. Platform (various accessories)
8. Socket for Charger
9. Chassis
10. Front Wheel

## TECHNICAL PROPERTIES

SKU	MEE100	MES150
Load Capacity	100kg	150kg
Load Centre (C)	235mm	235mm
Min. Platform Height (H1)	130mm	130mm
Max. Platform Height (H2)	1700mm	1500mm
Platform Size (L x W)	470 x 600mm	470 x 600mm
Overall Dimensions (L x W x H)	870 x 600 x 1990mm	870 x 600 x 1790mm
Front Wheel (d)	Ø75mm	Ø75mm
Rear Wheel (D)	Ø125mm	Ø125mm
Battery	24V / 12Ah	24V / 12Ah
Charging Period	10-12 hours	10-12 hours
Weight (kg)	62kg	65kg

This specification datasheet is provided for reference purposes only and does not constitute a guarantee of performance or features. The manufacturer reserves the right to make changes without prior notice. For the most accurate and up-to-date information, please refer to the user manual and the labels affixed to the equipment.

**Melbourne Head Office**  
**P:** (03) 8791 5777  
**E:** melbourne@teamsystems.net.au

**Adelaide Branch**  
**P:** (08) 8340 4111  
**E:** adelaide@teamsystems.net.au

**Sydney Branch**  
**P:** (02) 9609 7782  
**E:** sydney@teamsystems.net.au

**Perth Branch**  
**P:** (08) 9455 4855  
**E:** perth@teamsystems.net.au

**Brisbane Branch**  
**P:** (07) 3807 9144  
**E:** brisbane@teamsystems.net.au

**New Zealand Branch**  
**P:** 9 887 4647 **W:** teamsystems.co.nz  
**E:** auckland@teamsystems.co.nz

